

## NORMAQUICK® – Quick Connectors

### NORMAQUICK® MK Connecting spigot

NORMAQUICK® MK connectors have been developed with the aim to achieve significantly reduced permeation rates. NORMAQUICK® MK provide a perfect link between the tank

and the pipe system in cases where existing standard connectors are prone to a high permeation rate while their tendency to “creep” causes additional micro leakage.

NORMAQUICK® MK for the first time combine reinforced and unreinforced materials and thus enable the safe connection of the connector with the plastic fuel tank.

### Short description of technical features

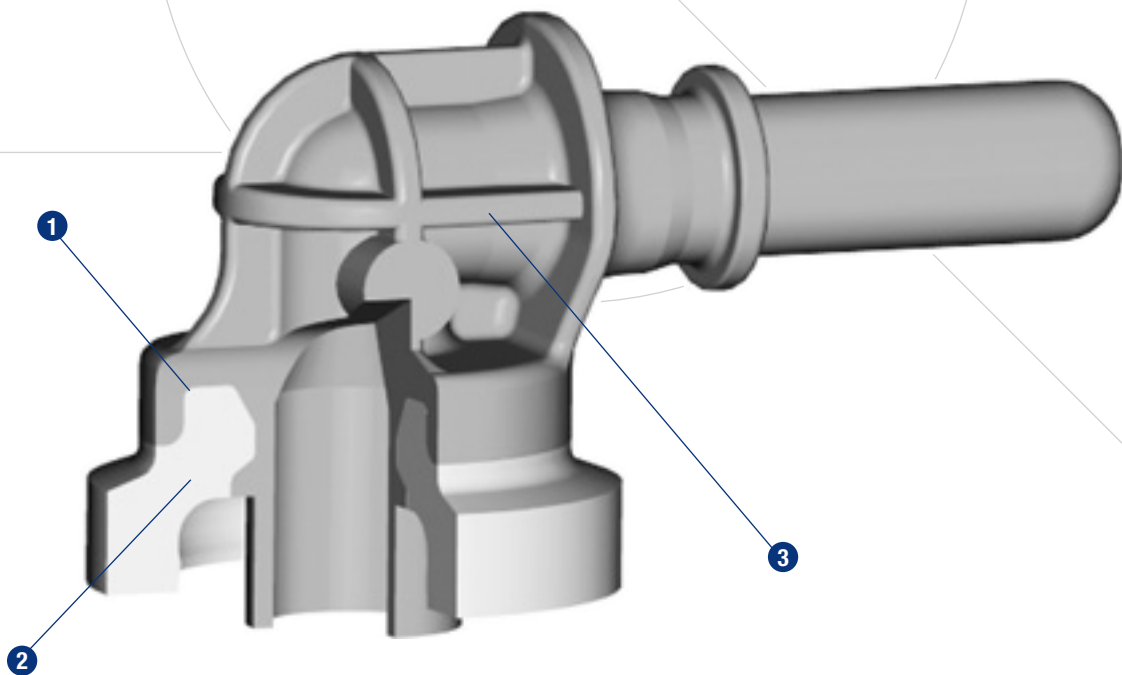

- 1 Chemical bonding
- 2 Welded ring HDPE
- 3 Spigot PA 12 (glass fiber reinforced)

### Materials

NORMAQUICK® MK combine materials that so far have been incompatible. Welded ring made from HDPE, can be welded onto the plastic fuel tank. Spigot made from Polyamide 12 with 30 % glass fiber content.

# NORMAQUICK® – Quick Connectors

## Connecting spigot

NORMAQUICK® MK are applicable for use with the following connectors:

- SAE (e.g. NORMAQUICK® S)
- VDA (e.g. NORMAQUICK® PS 3)
- NORMAQUICK® V2
- Firtree

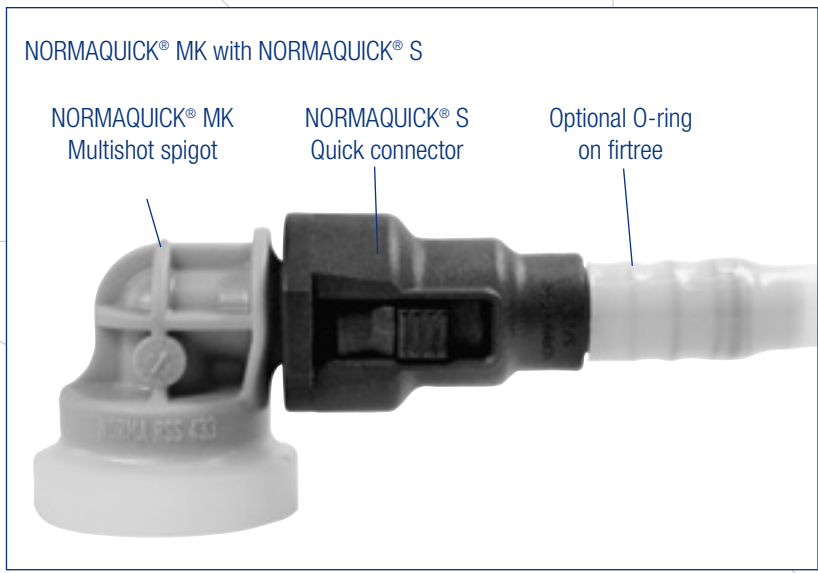

## Insiders' Tip:

The perfectly matched system is achieved when combining NORMAQUICK® MK connecting spigots and NORMAQUICK® S Quick connectors with NORMAQUICK® V2 and Firtree fluid systems.

Comparison of permeation rates Shed test to Carb Specification

## Technical features

- Meeting the requirements of ENG standard 016, VW TL 82417 and KT-2KDL-0802

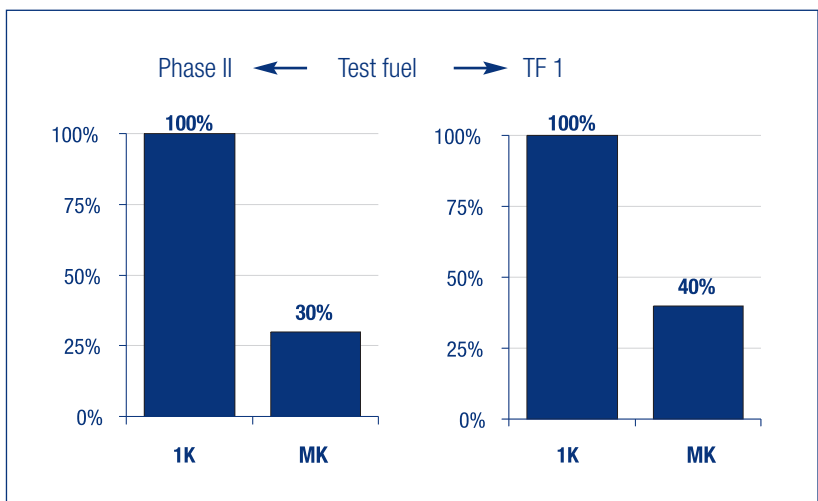

Reduced permeation achieved by means of MK connectors

## The advantages at a glance

- Drastically reduced permeation rates at the connection between the plastic fuel tank and the fuel lines by means of a 2-component material mixture
- Very good physical and chemical properties

# NORMAQUICK® – Quick Connectors

## Survey of sizes NORMAQUICK® MK

The NORMAQUICK® MK is not a standard part. All projects are based on special customer requirements. We shall therefore be pleased to receive a precise description of your application in order to be able to offer you an optimal, customised solution.

## Applications

- Fuel tank ventilation systems
- Fuel tank filler systems

## Connector types

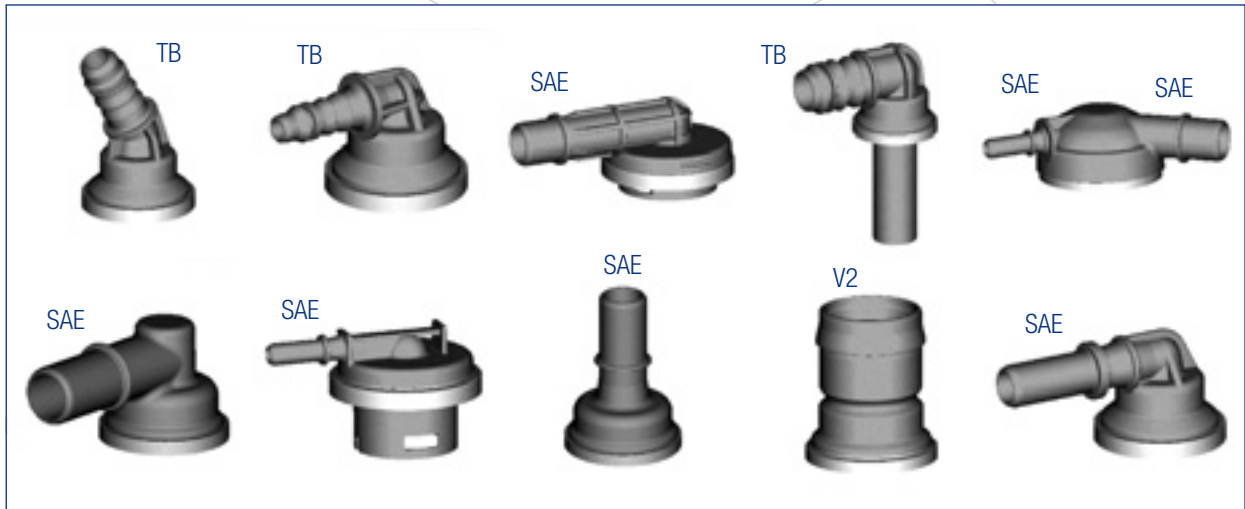

TB: Firtree  
V2: NORMAQUICK® V2  
SAE: Connecting spigot to SAE



NORMAQUICK® MK